

DETERMINATION OF YARN LENGTH IN WARP BEAMS FOR SIZING

HAŞILLAMA İÇİN HAZIRLANAN ÇÖZGÜ LEVENTLERİNDE İPLİK UZUNLUĞUNUN BELİRLENMESİ

Resul FETTAHOV*, Mahire CIHANGIROVA, Yalcin YESIL

*Bartın University, Faculty of Engineering, Department of Textile Engineering,
74100, Bartın, Turkey*

Received: 11.11.2015

Accepted: 28.06.2016

ABSTRACT

There has been a vast amount of attempts in the weaving companies for reducing the production costs without compromising the product quality. One of the most common methods is the reduction of yarn waste produced during weaving. In this study, theoretical investigations were carried out for determination of the yarn length wound beams, prepared in sizing and warp transfer processes, for reducing the yarn wastes. In addition, equations which determine the length of yarn to be wound on separate beams of different types of creels in sizing machines have been developed and proposed for practical use.

Keywords: Weaving, Sizing process, Yarn wastes, Warp beam, Yarn length

ÖZET

Dokuma işletmelerinde ürünün standart kalitesine zarar vermeden üretim maliyetlerinin düşürülmesi ile ilgili birçok çalışma yapılmıştır. Bunlardan en önemlisi dokuma üretimi aşamalarında oluşan iplik atıklarını azaltarak hammadde olan ipliğin rasyonel kullanımının sağlanmasıdır. Bu çalışmada, iplik teleflerini azaltmak amacıyla haşıl ve çözgü aktarma işlemlerinde hazırlanan leventlere sarılan iplik uzunluklarının tespiti için teorik incelemeler yapılmıştır. Ayrıca haşıl makinelerinde farklı tip çözgü sehparında yerleştirilen ayrı ayrı leventlere sarılacak iplik uzunluğunu belirleyen denklemler geliştirilmiş ve pratikte uygulanması önerilmiştir.

Anahtar Kelimeler: Dokuma üretimi, Haşıl işlemi, İplik tepleri, Çözgü leventi, İplik uzunluğu

Corresponding Author: Corresponding Author: Resul FETTAHOV, resulf@bartin.edu.tr

1. INTRODUCTION

One of the most suitable ways to efficiently benefit from the yarn during weaving is to minimize the yarn waste generated during the production. The maximum amount of yarn waste is produced during the sizing process in the preparation stage of weaving [1,3]. Accordingly, various studies have been carried out for preparation of warp beams as an attempt to increase the efficiency of the sizing machines [4-7]. As one of the most complex steps in fabric production, sizing plays a very important role in the weaving process. The primary purpose of the sizing process is to obtain the warp yarns, most likely to be woven without major damages during the passage of yarn through the sliding metal parts of the weaving machine [8,9]. Thus, the weaving efficiency is increased and quality of the produced fabric is improved during the sizing process.

Most of wastes in sizing process are due to the non-sized ends. The reason behind it is the differences of yarn lengths occurred between different beams. Several equations have been proposed in order to estimate the wound yarn length on the beam during warping while considering parameters such as sizes of beam and structure of winding. For instant, Zaitsev determined the length of wound yarn on the beam according to the value of the rotation angle [10]. Also Simon and Hübner reported that there are theoretical equations presenting the relation between the yarn length wound on the beam and the winding structure of the beam such as winding diameter, winding density, thickness of wound yarn and number of yarn etc. [1]. Vlasov et al., Loktyusheva and Bogorach reported theoretical equations calculating the yarn length according to the number of wound yarn, the weight of yarn on the beam and the sizes of beam [11, 12]. These equations proposed have been used in order to estimate the

length of wound yarn onto the beam and the relation between the yarn length and factors affecting the length. Besides, Zaitsev and Machover investigated the factors affecting the distance among the wound yarns on the beam and the effect of length differences to the yarn stress during wrapping [13, 14].

Two kinds of yarn waste, namely non-sized (raw) and sized waste are produced in the following parts of the sizing machine [3, 15].

- Sized yarns with a length of l_1 cut between sizing vessel and front comb,
- Raw yarns with a length of l_2 cut between the first warp beam and sizing vessel,
- Raw yarns with a length of l_3 between the first warp beam and other beams,
- More wrapped reserve yarn with a length of l_4 in order to prevent early end of the warp yarn on beam,

The total length of yarn wastes occurred from a beam line in sizing would be:

$$l_{\text{waste}} = l_1 + l_2 + l_3 + l_4 \quad (1)$$

In this equation, the length of the yarns other than l_3 is accepted constant for all sizing machines. The length of l_3 yarn between the first warp beam and other beams is variable for each beam. This length must be calculated depending on the type of warp creel. However, l_2 and l_4 together are given as mean values in the references [3, 15]. Here, the effect of l_3 is indicated by the following equation

$$l_4 \cdot \frac{k-1}{k} \quad (2)$$

where, l_4 is the length of yarn remaining on the warp beams after finishing the process in a lineup, and k is the number of the beams on a warp creel. According to equation (2), the effect of the number of the beams (k) on the length of yarn waste decreases with increasing k . When $k = 1$, the equation (2) is equal to zero. So, when one warp beam is used in sizing, no yarn remains on the beam. Whereas, wrapping spare yarn with l_4 length onto each wrap beam prepared for sizing is inevitable. The length of spare yarn must be determined according to the value of l_3 . Otherwise, the required length of the yarn which is wound on different beams cannot be identified correctly.

The aim of this study is to determine the length of l_3 end, and to identify the real length of the wound yarn on the beams for different creels of sizing machine and different locating of beams. In the study, for different constructed wrap creels of sizing machine and for different beam aligning case in application, theoretical equations presenting l_3 length of the yarn between first wrapping beam and other beams according to their geometrical sizes and the length of yarn required on the beams by depending on the l_3 were obtained.

2. METHOD

The Required Length of Yarn on a Warp Beam

The required length of the yarn which is wound onto wrap beam depends on the length of the yarn on the weaving beam.

During the sizing process, n weaving beams with a length of L_d are obtained from a warp lineup on sizing machine creel. At the end of this process, sized and non-sized (raw) yarn waste, with a total length of l_{waste} , is produced. Accordingly, the length of yarn to be wrapped on each warp beam taking into account the yarn waste, shall be

$$L_C = nL_d + l_{\text{waste}} \quad (3)$$

Where; L_d —The length of yarn wrapped on the weaving beam

n —The number of weaving beams on a warp lineup

During sizing, yarn is exposed to shrinkage with size of at the regions between warp beams and woven beam. Therefore, elongation occurs in the (nL_d), l_1 , l_2 , l_3 portions of the yarn unwound from the beam. The spare yarn with length of l_4 at the bottom of the beam is not exposed to elongation since it is not affected by shrinkage. In this case, the increase in the length due to the elongation during sizing process will be:

$$\delta L = (nL_d + l_1 + l_2 + l_3)0,01\zeta \quad (4)$$

where; ζ is the shrinkage occurring during the sizing process. It varies within the range of 0.5% and 1.5% depending on the type of machine and kind of the yarn [15].

When calculating the required length of yarn wound on the beam in the warping process, δL is subtracted from the L_C . In this case, in consideration of elongation occurred in the sizing process, the required length of yarn to be wound on the warp beam is calculated by the following equation.

$$L_y = L_C - \delta L = (nL_d + l_1 + l_2 + l_3)(1 - 0,01\zeta) + l_4 \quad (5)$$

All the parameters other than l_3 are assumed constant in Equation (5). Accordingly, the l_3 value must be calculated in order to determine the required length of the yarn to be wound on the beam. The length of each beam varies depending on the location of the warp beam on the creel as well as the warp feeding method.

3. CALCULATION OF THE LENGTH l_3 ON THE CREELS

3.1. Calculation of the Length l_3 for Roll-Over-Feed Single Level Creel

The placement of the beams in a single level creel, operated with roll over feed method, is shown Figure 1.

Here, AC as the distance between the first and the second beams, AD as the distance between the first and the third beams, AE as the distance between the first beam and $k-1$ st beam, and AM as the distance between the first and k st beam, together corresponds to the length l_{zs} .

In Figure 2, the distance between the first beam and the second beam is:

Since

$$\vec{ab} = \vec{ca} = ra \quad (6)$$

$$l_{zs} = \vec{ab} + bc + \vec{ca} \quad (7)$$

$$l_{zs} = 2ra + bc \quad (8)$$

Where, r – is the radius of the yarn remaining at the bottom of the beam which can be taken equal to the radius of the

beam body, and α – is the total angle of the yarn covering the beam face.

The value of coverage angle α is obtained from the O_1bs triangle as shown in Figure 2;

$$\sin\alpha = r/O_1s = r/(a/2) \quad (9)$$

From equation (9),

$$\alpha = \arcsin(r/(a/2)) \quad (10)$$

$bc = be + ec$ and $be = ec$, so, $bc = 2bs$ from Figure 2.

In the triangle O_1bs :

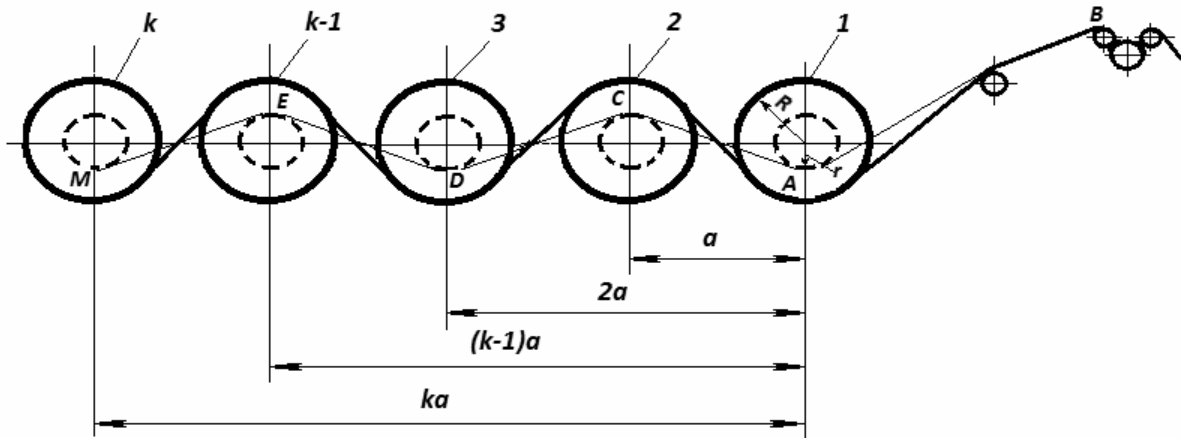

Figure 1. The placement of the beams on single level creel.

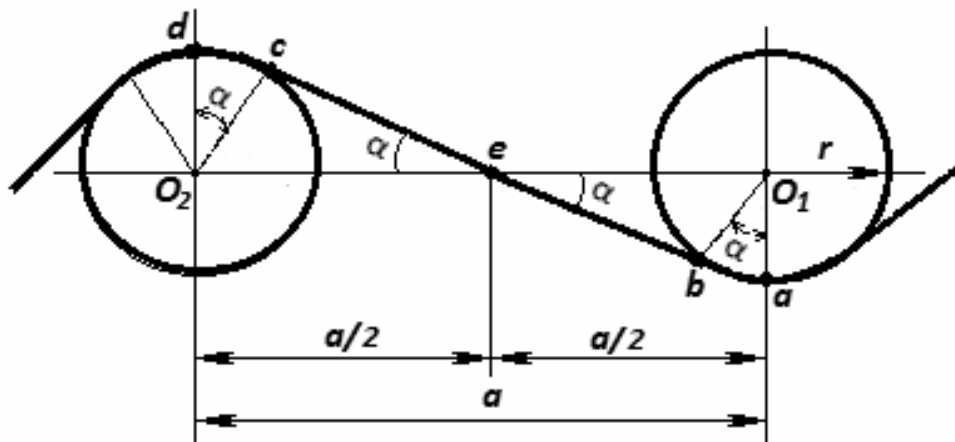

Figure 2. Calculation of yarn length between the beams in single level creel.

$$be = O_1e \cos \alpha = \left(\frac{a}{2}\right) \cos \alpha \quad (11)$$

So,

$$bc = 2be = a \cos \alpha \quad (12)$$

Where; a – is the distance between the vertical axes of the beam.

Using α and be values in Equation (8), the final equation giving $l_{2,2}$, is obtained.

$$l_{2,2} = 2r \cdot \arcsin\left(\frac{r}{(a/2)}\right) + a \cos \alpha \quad (13)$$

The length of yarn between the third beam and the first beam is $l_{3,3} = AC + CD$ (Figure 1). Since $AC = CD = l_{2,2}$ as the distance between the beams, a , is constant,

$$l_{3,3} = 2AC = 2l_{2,2} \quad (14)$$

$$L_{GK} = \left\{ n l_a + l_1 + l_2 + (k-1) \left[2r \cdot \arcsin\left(\frac{r}{(a/2)}\right) + a \cos \alpha \right] \right\} (1 - 0,01\zeta) + l_4 \quad (16)$$

According to this rule, for the yarn length between the k^{st} beam and the first beam, the following equation is obtained:

$$l_{2,k} = (k-1)l_{2,2} = (k-1) \left[2r \cdot \arcsin\left(\frac{r}{(a/2)}\right) + a \cos \alpha \right] \quad (15)$$

equation is obtained.

Thus, the length of required yarn to be wound on the warp beam for use in the roll over feed single-level creel machine, is calculated by the following equation;

For the first beam, k is taken as zero.

3.2. Calculation of l_2 for Sequential-Feed Double-Level Creel

The length of $l_{2,2}$ yarn between the second beam and the first beam on a sequential-feed two-level creel (Figure 3 and Figure 4);

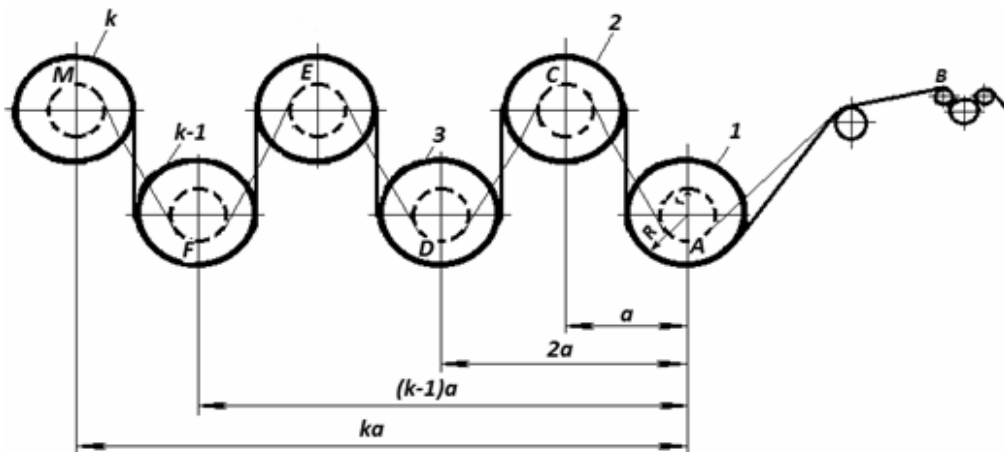

Figure 3. Location of the beams on a double-level creel.

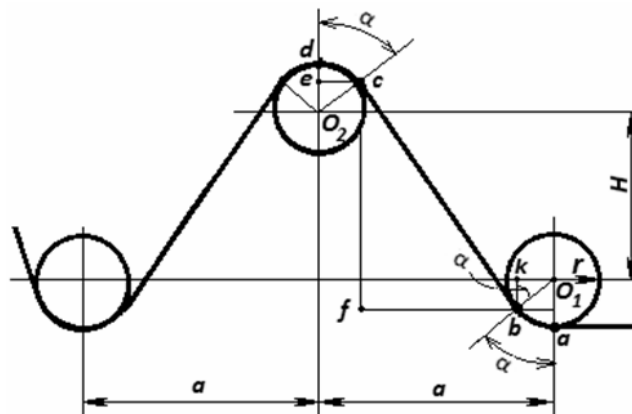

Figure 4. Calculation of the yarn length between the beams in a sequential-feed double-level creel.

$$l_{3,2} = ad = \vec{ab} + bc + \vec{cd}$$

$$\text{so, } \vec{ab} - \vec{cd} = ra,$$

and

$$l_{3,2} = 2ra + bc \quad (17)$$

that

From *bfc* triangle

$$bc = \sqrt{bf^2 + cf^2} \quad (18)$$

and

$$bf = a - 2r \cdot \sin\alpha \quad (19)$$

$$cf = H + 2r \cdot \cos\alpha \quad (20)$$

Using these values, the following Equation (21) is obtained:

$$bc = \sqrt{a^2 + H^2 + 4r(H \cdot \cos\alpha - a \cdot \sin\alpha) + 4r^2} \quad (21)$$

By using *bc* in Equation (17):

$$l_{3,2} = 2ra + \sqrt{a^2 + H^2 + 4r(H \cdot \cos\alpha - a \cdot \sin\alpha) + 4r^2} \quad (22)$$

is obtained

$$l_{3,2} = 2r \left[90^\circ - \arcsin \sqrt{1 - \frac{4r^2}{H^2 + a^2}} + \arctan(H/a) \right] + \sqrt{a^2 + H^2 + 4r(H \cdot \cos\alpha - a \cdot \sin\alpha) + 4r^2} \quad (25)$$

$$l_{3,k} = (k-1)l_{3,2} = (k-1)2r \left[90^\circ - \arcsin \sqrt{1 - \frac{4r^2}{H^2 + a^2}} + \arctan(H/a) \right] + \sqrt{a^2 + H^2 + 4r(H \cdot \cos\alpha - a \cdot \sin\alpha) + 4r^2} \quad (26)$$

$$L_{3k} = \left\{ aL_a + l_1 + l_2 + (k-1)2r \left[90^\circ - \arcsin \sqrt{1 - \frac{4r^2}{H^2 + a^2}} + \arctan(H/a) \right] + \sqrt{a^2 + H^2 + 4r(H \cdot \cos\alpha - a \cdot \sin\alpha) + 4r^2} \right\} (1 - 0,01C) + l_4 \quad (27)$$

The coverage angle α in the equation can be calculated using the equation obtained in reference [15].

$$\alpha = 90^\circ - \arcsin \sqrt{1 - \frac{(R_1 + R_2)^2}{H^2 + a^2}} + \arctan(H/a) \quad (23)$$

Since R_1 and R_2 in Equation (23) indicates the radius as the top and bottom floor of the beam trunk, equation is configured as follows

$$\alpha = 90^\circ - \arcsin \sqrt{1 - \frac{4r^2}{H^2 + a^2}} + \arctan(H/a) \quad (24)$$

As the value α is written in Equation (12), the latest version of the equation, used in the calculation of $l_{3,2}$, is obtained.

And the length of yarn between the first beam and *k* beam is;

The required length of yarn to be wound on the beams can be calculated by Equation (27)

3.3. Calculation of l_3 for a Quadruplet-Feed Double Level Creel

The location of the beams on a quadruplet-feed two-level creel is given in Figure 5 and Figure 6 [15].

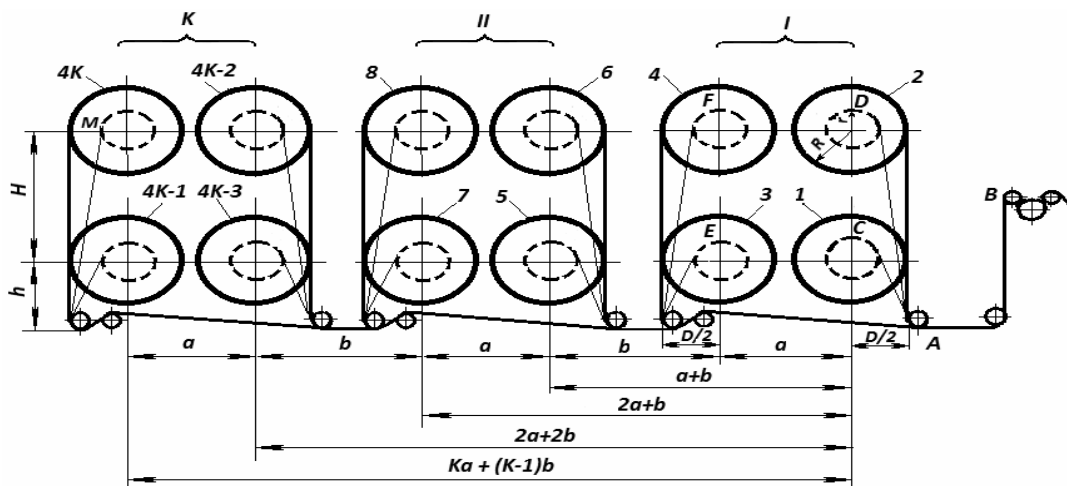

Figure 5. The location of the beams on a quadruplet-feed double-level creel.

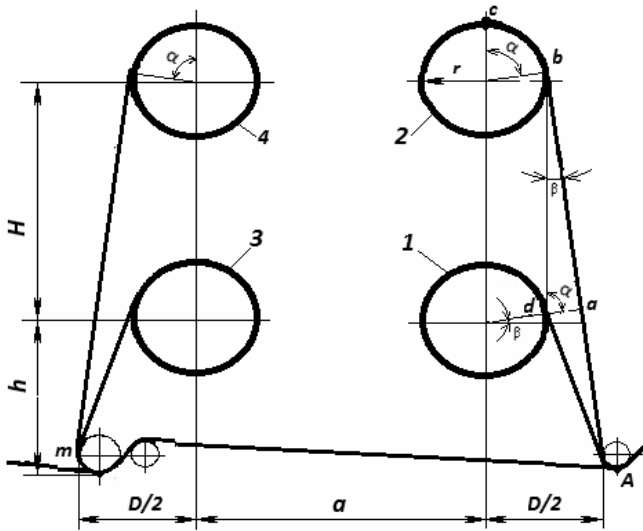

Figure 6. Calculation of the yarn length between the beams in a quadruplet-feed double-level creel.

Here $2, 4, \dots, K$ beams are located in in two levels and in I, II, \dots, K groups each having four beams (Figure 5). Beams on the lower level of the creel are shown as $1, 3, \dots, K-1$ and the beams on the upper level are shown as $2, 4, \dots, K$. Here a indicates the horizontal distance between two beams of the group, while b refers to the horizontal distance between the two groups of adjacent beams.

In Figure 6 the length of the yarn between the second beam located on the top level of the first group ($K=1$) and first beam in the bottom level is $l_{32} = ab + \overline{bc}$, since $\overline{bc} = r\alpha$ is $l_{32} = ab + r\alpha$. On the other hand, it is seen that $\alpha = \pi/2 - \beta$. Here the value $\alpha = \pi/2$ is tolerable with a small error due to the negligible value of β . In this case ab can be considered equal to H . Accordingly:

$$l_{32} = H + r\pi/2 \quad (28)$$

The distance Am between first beam and the third beam of this group, as shown in Figure 6:

$$l_{33} = a + D/2 + D/2 = a + 2R \quad (29)$$

is calculated using the equation (Am length is accepted linear). The yarn length between the first beam and the fourth beam is calculated by Equation (30).

$$l_{34} = a + 2R + H + r\pi/2 - a + 2R + l_{32} \quad (30)$$

In this case the yarn length of the beams between the first beam of the first group and the beams within K . group is calculated as follows:

The length of the yarn between the front beam in the lower level ($4K-3$) and first beam:

$$l_{3(4K-3)} = (K-1)a + (K-1)b \quad (31)$$

The length of the yarn between the rear beam in the lower level ($4K-1$) and first beam:

$$l_{3(4K-1)} = Ka + (K-1)b + 2R \quad (32)$$

The length of the yarn between the front beam in the upper level ($4K-2$) and first beam:

$$l_{3(4K-2)} = (K-1)a + (K-1)b + H + r\pi/2 \quad (33)$$

The length of the yarn between the rear beam in the upper level ($4K$) and first beam:

$$l_{3(4K)} = Ka + (K-1)b + 2R + H + r\pi/2 \quad (34)$$

Here, K – is the ordinal number of quadruplet groups. For example, $K=1$ for group I , $K=2$ for group II . In this case, the required length of yarn to be wound on the bottom of the front beam can be calculated with Equation (35) and the required length of the yarn to be wound on the upper level of the rear beam can be calculated with Equation (36).

$$L_{3r} = [nl_d + l_1 + l_2 + (K-1)a + (K-1)b](1 - 0,01\zeta) + l_4 \quad (35)$$

$$L_{3k} = [nl_d + l_1 + l_2 + Ka + (K-1)b + 2R + H + r\pi/2](1 - 0,01\zeta) + l_4 \quad (36)$$

3.4. Calculation of l_{33} for Medial-Free-Feed Double-Level Creel

The l_{33} length of yarns cut between the first beam and other beams according to layout of the beams in medial-free-feed two-level creel is calculated according to Figure 7 and Figure 8.

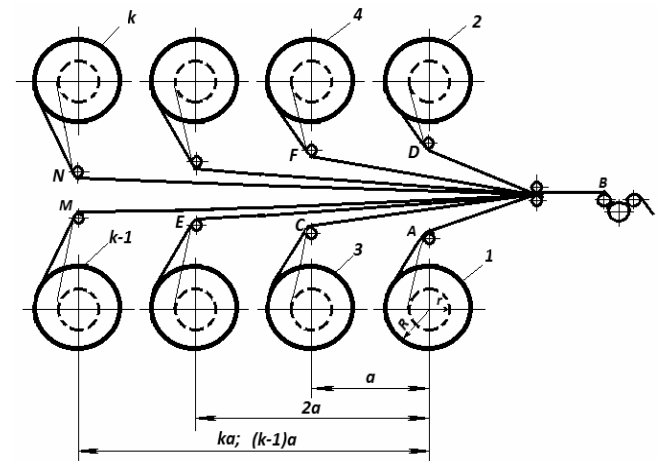

Figure 7. Location of the beams on a medial-free-feed two-level creel.

Here, due to the symmetrical placement according to the center line of the upper and lower beams, the yarn lengths unwound in the same vertical plane of the beams are equal to each other. Therefore the length l_{33} between first beam and third beam, second beam and fourth beam will be equal. According to Figure 8:

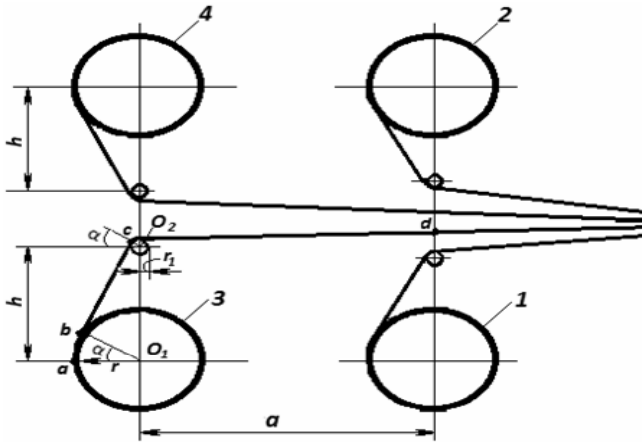

Figure 8. Calculation of the yarn length between the beams in a medial-free-feed two-level creel.

$$l_{2,3} = l_{3,4} = ac + cd \quad (37)$$

Since, radius r_1 of directing cylinder is very small compared to radius r of the beam body, the length of yarn ac can be approximately calculated by the following equation with a small error

$$ac = \sqrt{r^2 + h^2} \quad (38)$$

Since, $cd = a$ Equation (39) is obtained.

$$l_{2,3} = l_{3,4} = ac + cd = \sqrt{r^2 + h^2} + a \quad (39)$$

The yarn length between the first beam and the fifth beam, second beam and the sixth beam:

$$l_{2,5} = l_{3,6} = \sqrt{r^2 + h^2} + 2a \quad (40)$$

The length of yarn between the first beam and $(k-1)$ beam, second beam and k beam:

$$l_{2,(k-1)} = l_{3,k} = \sqrt{r^2 + h^2} + (k-1)a \quad (41)$$

The required length of the yarn to be wound on the beams in a medial-free-feed two-level creel can be calculated using the following equation.

$$L_{CK} = [nL_d + l_1 + l_2 + \sqrt{r^2 + h^2} + (k-1)a](1 - 0,01\zeta) + l_4 \quad (42)$$

4. CONCLUSION

One of the important factors affecting yarn waste generated from sizing and warp transfer process is the length of the yarn wound on the warp beam and the number of the beams in a row. The elongation of the yarn, construction of warp creel on the sizing machine and the array of the beam used must be considered on determining (adjustment) the length of the yarn on warp beam that are prepared for these processes.

The yarn length must be calculated according to factors such as the locations of the beams, warp feeding method and warp creel type for fulfilling the sizing or transfer process with the lowest waste.

In current applications, when the same length of the yarn is wound on array of the warp all beams, different lengths of the yarn waste are left at the end of the process. In this study, according to the construction of the different warp creels and the different arraying of beam in application, theoretical equations determining the length of the yarn between the first warp beam and the other beams and the length of the yarn required on separately located beams were obtained. When these equations have been used different length of the yarn will be wound on every beam which is put onto creel. As a result of it, almost the same length of the yarn will be wasted for all beams after completing the process.

REFERENCES

- Simon, L., and Hübner, M., 1983, "Preparation technique for weaving, knitting and hosiery", Ed. Simon, L., Knitting and Hosiery, No:1, Springer-Verlag Berlin Heidelberg, p. 392. (Deutsch)
- Behera, B.K., Mishra, R. and Gupta, R., 2008, "Comparative analysis of mechanical properties of size film, II. Effect of blend composition and lubricants", *Fibers and Polymers*, 9(4), p. 489-494.
- Gordeev, V.A. and Volkov, P.V., 1984, "Weaving", *Legkaya Pishchevaya Prom-st w*, p. 151, Moscow. (Russian)
- Seyam, A., 2000, "Advances in Weaving and Weaving Preparation", *Textile Progress*, 30(1-2), p. 22-40.
- Eren, R., 2009, "Dokuma Hazirlık Sistemleri", *MKM Yayınları*, Bursa.
- Gubin, V.V. and Makarov, A.A., 2012, "Device for measuring the length of the warp wound on the warp beam or warp shaft of a sectional or high-speed warping machine", *Fibre Chemistry*, 44(1), p. 61-63.
- Karahan, H.A., et al., 2007, "Some Methods Used for the Surface Modification of Textiles", *Tekstil ve Konfeksiyon*, 17(4), p. 248-255.
- Goswami, B.C., Anandjiwala, R.D. and Hall, D., 2004, "Textile sizing", *CRC Press*, p. 243-247.
- Djordjevic, S., et al., 2012, "Importance of Polymer Size Rheology for Efficient Sizing of Cotton Warp Yarns", *Tekstil ve Konfeksiyon*, 22(2), p. 77-82.
- Zaitsev, V. P., 1968, "The dependence of the yarn length wound on warping package at from the angle of its rotation", *Proceedings of the Universities, The technology of the textile industry*, No:5, p. 70-73. (Russian)
- Vlasov, P. V., Martinov, A. A., Nikolaev, S. D., et al., 1983, "Design of weaving factories", 2nd Ed., Rev. and ext., p.303, Moscow. (Russian)
- Loktyusheva, V. I., Bogorach, P. C., 1987, "Design of weaving factories", *Legprombytzdat*, p.264, Moscow. (Russian)
- Zaitsev, V. P., 1970, "On the equality of lengths of yarn wound on the warping beam", *Proceedings of the Universities, The technology of the textile industry*, No:3. (Russian)
- Zaitsev, V. P., Machover, V. L., 1973, "Effect of different yarns length in warping winding shaft to deformation them in the process of winding", *Proceedings of the Universities, The technology of the textile industry*, No:4, p. 71-76. (Russian)
- Volkov, P.V., Gordeyev, V.A. and Nikiforov, S.I., 1971, "Design of Weaving Factory", *Lyogkaya Industriya*, p. 488, Moscow. (Russian)