

The Impact of 'Distribution Capability, Business Knowledge, Service Differentiation and Experience' Firm Behaviors on Export Performance

¹Dr. Orhan Bozkurt, ²Dr. Şaban Esen

¹Bartın University, Faculty of Economic and Administrative Sciences, Department of Business Administration

²Bartın University, Faculty of Economic and Administrative Sciences, Department of Business Administration

Abstract: The main purpose of this study is to investigate the effect of distribution capability, service differentiation, business knowledge and experience of businesses on export performance. Accordingly, meetings based on research were arranged, models were developed and which business behaviours of manufacturing companies doing international sales have positive impacts on business performance of those companies was examined. To support the hypothesis, a questionnaire was conducted to the senior executives of businesses in Turkey which are doing international sales. To determine the factors that can contribute to the export performance, research-based view (RBV) was applied and the results obtained were analyzed. The findings of the study revealed that increasing the distribution capacity, service differentiation and knowledge and experience of a business impacted the export performance positively. Other findings and arguments were included as well.

Key words: *Distribution capability, service differentiation, business knowledge, experience, business, export performance*

INTRODUCTION

In today's world, we see that the businesses are operating in a hypercompetitive business environment. This increasing competition makes export a necessary element for companies' sustainability (Leonidou and Constantine, 1996). The target is to increase sales revenue of businesses through export. A large part of exports of countries' is done by the Small and Medium Sized Enterprises (SMEs). These companies account for 40% to 80% of total employment and 30% to 60% of their countries' gross national product (GNP) (Srodes, 1998). Those companies can accommodate technological innovations and environmental changes (Keng and Juan, 1989; Yaprak, 1985) quite easily. On the other hand, penetrating into an export market and competing in this market is rather challenging. Among the barriers in penetrating into export markets are lack of information about foreign markets and connections, the sophisticated structure of export certification and ambiguities (Bilkey and Tesar, 1977; Rabino, 1980; Bilkey, 1978). There are opportunities in those markets (Antti *et al.*, 2005) as well as barriers in entering them. Penetrating into new markets is an attractive and focused (e.g. Katsikeas, Leonidou and Morgan 2000; Cavusgil and Zou, 1994; Katsikeas, Piercy, 1988; N.F. and Ioannidis, 1996; Aaby and Slater, 1989; Toften, 2005, 2000; Kaynak and Kuan, 1993; Grimes, Doole and Kitchen, 2007; Toften and Olsen, 2003) issue in the literature. Export performance issue, however, has not been precisely defined yet (Leonidou, Katsikeas, and Piercy, 1998). The effects of various variables on export performance have been examined in the literature. (e.g. Dichtl *et al.* (1990); firm size to export performance Katsikeas *et al.* (1997); export market planning to export performance and Export knowledge to export performance; Export knowledge to export performance Toften and Olsen (2003); export marketing capabilities to export performance Aaker (1991); market information use to export performance Richey and Matthew (2001); delivery capability to export performance Stanley *et al.* (1997); quality and cost to export performance Stanley *et al.* (2000); Low-cost advantage and Branding advantage to export performance Shaoming Zou *et al.* (2003). and knowledge intensity to export performance Antti Hahti (2005); Product Adaptation Strategy to export performance Roger J. Calantone *et al.* (2006); Export Market Orientation to export performance Catherine Dodd (2005). Much attention in the literature focuses on the importance of firm costs and its influence on firm performance (e.g., Stanley *et al.*, 2000; Shaoming Zou *et al.*, 2003;). These studies examine which behaviours impact the export performance of a company and which do not. This study that we present both concerns theoretical and administrative view. In the past studies on export performance, companies in Turkey and their administrative perspective was not discussed in detail. Ever-growing Turkish business markets grab the attention of international investors. Our study, in this context, reflects the opinions of Turkish business managers. The purpose of this study is to examine if elements like distribution capability, service differentiation, business knowledge and experience, which impact the export performance in literature, reduce the export costs of Turkish companies and thus, to examine if they improve their export performances by using resource-based view (RBV). To find answers to this issue and suchlike, we applied a structural equation methodology to data

Corresponding Author: Dr. Orhan Bozkurt, Bartın University, Faculty of Economic and Administrative Sciences, Department of Business Administration

gathered from an industry sample of top managers. Export performance was assessed (Davis *et al.*, 2002) using two measures of profitability—return on assets (ROA) and return on sales (ROS). Profitability and increase in sales revenue is accepted as a good performance criterion in the literature (Dean *et al.*, 2000). This study includes five sections: In the first section, the overall scope of the study is set and the methodology used in the literature is explained. In the second section, the studies in the field are summarized. In the third section, a model is developed. In this section, dependent and independent variables regarding export performance are included as well as modeling and data collection; and statistical analysis. The results of the study and discussions are covered in the fourth section. Finally, in the fifth section, a closing discussion on the limitations of the study and on future researches was included.

2. Literature Review and Research Hypothesis:

2.1. Conceptual Framework:

With the growing importance of export, researchers working on company performance begin to show more interest in resource-based view studies (e.g., Morgan *et al.*, 2006). Resource-based view and export market context suggest two types of assumptions ideally (Zou *et al.*, 2003). One being resource heterogeneity and the other being resource immobility (Barney 1991). Resource-based view is an applicable method for setting up the theoretic environment in industrial export performance studies (Morgan *et al.*, 2006). The concepts examined in this study are distribution capability, service differentiation, business knowledge, experience and business export performance. Previous studies indicated that (Stanley E. *et al.*, 2000; Shaoming Zou *et al.*, 2003; Antti Haahti *et al.*, 2005; Kjell Toften, 2005) export market in formation use affects both the export cost and export performance. Utilizing this resource-based view (RBV) the model in Fig. 1 is developed. This conceptual framework is based on the opinion that distribution capability, service differentiation, business knowledge and experience factors bring export advantage and by this way, the financial performance of the exporter grows. According to the results of this study, the behavioral factors of the company impacts the financial export performance of the business positively.

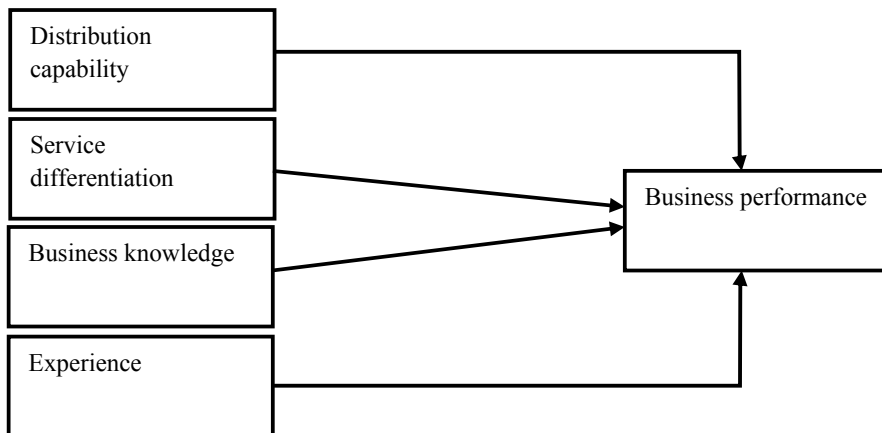

Fig. 1: The conceptual framework

2.2. Distribution capability:

With the advancements in technology the coordination of distribution channels of businesses widely gained importance (Anderson *et al.*, 1997). Companies can gain competitive leverage through their distribution channels (Day and Wensley, 1988; Bharadwaj *et al.*, 1993). In today’s world, strategies are developed according to the distribution at export markets (Grimes *et al.*, 2007). To gain competitive leverage through distribution channels the distribution capacity should be increased. Thus, it is necessary to reduce the expenses arising from distribution. Cost advantage, where product distribution to companies is provided with lower costs (Day and Wensley, 1988) can be regarded as a distinctive competition strategy. To get this advantage ways to increase the distribution capacity should be found. Distribution capacity is providing superior support for export distributors and being in close relation with them (Zou *et al.*, 20003). Effective communication with those distributors will ensure on-time delivery of goods and taking measures to prevent the occurrence of unanticipated costs. With an effective planning exporters can both reduce their distribution costs and establish an information network among in-country channel members (Richey and Matthew, 2001). Besides, as the distribution capability increases the company will make faster and on-time delivery. These on-time deliveries will contribute to the reduction of supplier’s costs and thus as the distribution capability of the company increases so does the financial performance. So;

H1. A business's distribution capability positively affects its export financial performance in the export market:

2.3. Service differentiation:

As stated by Morgan *et al.* (2004) being one of the business strategies, service differentiation is could be an option for businesses to be used for business export performance. Service differentiation strategy has been shown to contribute to successful performance and international growth (Porter 1980). Service differentiation strategies have impacts on financial performance. According to Porter strategy (1980, 1985) companies can gain competitive leverage either by cost leadership or by differentiation strategy. On the other hand, it is discussed that combining these two strategies will prove outstanding performance. The cost leadership strategy of a business can lead to above-average returns. That is because the business offers lower costs compared to its competitors. Through differentiated services and reduced costs the business can also achieve its sales targets and thus, it increases its sales and sales revenues. When applying differentiation strategy, the business should also consider non-operating factors that could be effective. Differentiation should be matching non-operating factors. To generate high revenue a business should make a different service differentiation compared to its competitors. Businesses offering effective service differentiation are preferred more by the customers. Using differentiation strategy provides business with performance superiority. Service differentiation ensures positional advantage in export market (Morgan *et al.*, 2004). By highly supporting customers, service differentiation improves the value of customer relations (Cavusgil and Zou 1994). In this case;

H2. A business's Service Differentiation Positively Affects Its Export Financial Performance In The Export Market:

2.4. Business knowledge:

Business knowledge is essential in export decisions (Richey and Matthew, 2001; BurrIDGE and Bradshaw, 2001; Toften and Olsen, 2003; Toften, 2005; Porter and Millar, 1985). In order to collect and use export market information it is important to develop direct and indirect good relations with customers. These relations will have positive impacts on company decisions. The company assesses the opinions of its customers regarding the product it sold. And as a result, the company leaves up those behaviours that do not contribute to the company, in other words, behaviours that do not reduce the costs or increase sales revenue. Besides, a company which is able to estimate the expectations in the export market would not manufacture goods or services that will not provide profit. Thus, with the cost advantage of using the obtained market information the company will not experience any problems about selling the products in the market. Business knowledge supports company in their channel adjustments and market adaptation (Richey and Matthew, 2001) Lack of information could be counted among the barriers in penetrating into a new market (Bilkey and Tesar, 1977). Performance can be measured based on the data obtained (Porac and Thomas, 1990). Information is highly important to be successful in marketing and to make right decisions (Song *et al.*, 2002). Exporters should therefore recognize the importance of relationship management in achieving superior export performance (Leonidou and Anna, 1998). Thus;

H3. A business's Knowledge Positively Affects Its Export Financial Performance In The Export Market:

2.5. Experience:

In today's world, export is an essential option to increase the sales revenue of businesses. It is important to enhance sales options by collecting export market information. Export decision-makers work to determine how much time is needed for market information and market resource research (Chetty, 1999). As stated by Morgan *et al.* (2004) policymakers should provide information aimed at ensuring direct experience for company executives, should ensure their attendance to business trips and organizations and thus, increase export experiences. Experience is highly important for companies because it is through experience that company can achieve making fewer mistakes and thus work with lower costs. Specific foreign market knowledge level of a company (Katsikeas and Morgan, 1994; Blesa and Ripollés, 2008) is related with its foreign market knowledge, awareness of export environment (Wang and Olsen, 2002;) and the impact of this knowledge on export performance. As specified by Barney (1991) experience plays an important role in achieving superior company performance as a means of value building. Executives take critical decisions by using their experiences (Porac and Thomas, 1990). To have a limited experience based on information about foreign partners (Leonidou and Anna, 1998) or competitors is a serious disadvantage for the company. With experience-based company knowledge opportunities in the market could be better evaluated. Develop new knowledge that enhances its international competitiveness (Shan and Song, 1997). With the addition of new information on the existing ones at the export market by means of implementation and reputation the number of mistakes arising from operation failures will decline and thus, additional costs will be prevented. In conclusion, decreasing costs will increase company's financial performance.

H4. A Business's Experiences Positively Affect Its Export Financial Performance In The Export Market.

2. 6. Firm Performance:

As company factors, distribution capability, service differentiation, business knowledge and experience positively impact the business performance (Stanley *et al.*, 1997; Catherine, 2005; Grimes *et al.*, 2007; Fraering, 1996; Katsikeas *et al.*, 1996; Zou *et al.*, 1998; Diamantopoulos *et al.*, 2003; Aaker, 1991; Richey and Matthew, 2001). In this respect, performance should be able to adapt to organization's environmental changes in reaching organizational objectives and performance outputs (Katsikeas *et al.*, 2000). While some studies focus on direct and indirect impacts on export performance of organizations (Rose and Shoham, 2002), some directly focus on export performance rather than how much companies are willing to engage in export business (Rose and Shoham, 2002); and other studies center on the fact that export performance is both related with internal and external factors (Calantone *et al.*, 2006). Previous studies defined export performance as (Dean *et al.*, 2000); (e.g., export profits, ratio of export profit to total profits, increase of importance of export to total business, acceptance of product by export distributor, etc.) It is expected that subjective criterion are more effective in measuring export performance and determining the style that the export performance is related to managerial decisions. (Katsikeas *et al.*, 2000). By taking risks and discovering the environmental changes well (Evangelista, 1994) exporters can use changes for their own advantage. This way, environmental opportunities makes positive impacts on export performances (Rose and Shoham, 2002). Business factors discussed in this study are based on the study of Zou *et al.*, 2003. Zou *et al.* Presents their study in a structural model based on the Day and Wensley's (1988) framework. In this model, they established a link between venture's export marketing capabilities (pricing capability, distribution capability, communication capability) and low-cost advantage; between this advantage and its performance. They suggest a positive relationship between pricing capability, distribution capability, communication capability and low-cost advantage as well as between low-cost advantage and export financial performance. And in our study, how much such factors like distribution capability, service differentiation, business knowledge and experience impact the business performance is analyzed.

3. Research Method:

3. 1. Data collection and analytical method:

In this research study, the elements that impact the business export performance of manufacturing companies, making export are analyzed. In the research, which behaviours of the businesses impacts the export performance positively is looked into. To do that, tested variables impacting the export performance in international literature are used and hypotheses are developed. To test the hypothesis and to look into the results of the established models, a questionnaire is conducted on businesses making export. In determining the businesses to which this practice was implemented, the lists of undersecretariat of the Prime Ministry for Foreign Trade are used and addresses are chosen among those lists. The chosen businesses are mostly located in the western part of the country and these businesses are among the businesses listed as Small and Medium Sized Enterprises (SMEs). Questionnaire method is chosen as the data collection method. In order to arrange the questionnaire questions, translations were made from English into Turkish. The scales in the questionnaire were elaborately prepared including internationally accepted questions with tested reliability and validity. Scales in articles published in international magazines were used to do this. Test questionnaires were done face-to-face. As a result of the questionnaires, necessary amendments were made in questions which were not clear and the questionnaire took its final form. Various difficulties can be faced since return by post is rare and takes a long time. Thus, collecting the questionnaires via post was not approved. While questionnaires were sent to businesses via e-mail, on one hand (80 questionnaires were sent), 160 questionnaires were applied face-to-face, on the other hand. Face-to-face meetings increased the questionnaire feedback rates. Each implementing person was given five questionnaires and was asked to apply them. These questionnaires were answered by business executives and business owners. After the answers to the questions were looked into, 80 questionnaires were considered invalid since they were negligently filled. Thus, the number of available questionnaires in this research was 140 and the feedback rate was around 58%. Five point likert scale was applied in all parts of the questionnaire. The questions of the questionnaire was prepared and research-based view (RBV) was applied to determine the factors that can contribute to the export performance. The obtained results were analyzed.

3. 2. Measurement model:

The business knowledge scale (1 = strongly disagree; 5 = strongly agree) in the questionnaire was measured in 2 questions and the questions were adapted from Richey and Matthew.(2001). Experience (1- very weak, 2- weak, 3- fair, 4- good, 5- excellent) was measured in 2 questions and the questions were adapted from Morgan *et al.*(2003). Distribution capability (1=Much Worse; 5=Much Better) was measured in 2 questions and the questions were adapted from Zou *et al.*(2003). Service differentiation (1=Much Worse; 5=Much Better) was measured in 3 questions and the questions were adapted from Morgan *et al.*(2004). And business export performance (1 = Not satisfied at all; 5 =Extremely satisfied) was measured in 4 questions and was adapted from Lages and Montgomery (2004).

RESULTS AND DISCUSSION

In analyzing the data in this research, SPSS 18.0 statistics program was used. As a result of factor analysis done, Cronbach's alpha reliability test was found sufficiently high (the lowest 77%). Besides, the correlation analysis and regression analysis including the average and standard deviations of the variables were made. Analysis and the findings are as below:

Table 1: Factor loading scores for the items

| Measurement item | Factors | | | |
|--|---------|------|------|------|
| | 1. | 2. | 3. | 4 |
| 1-Distribution capability | | | | |
| a- Satisfying the needs of distributors in this export market | .889 | | | |
| b- Adding value to distributors' businesses | .636 | | | |
| 2-Service differentiation | | | | |
| a- Achieving/maintaining quick product delivery | | .779 | | |
| b- Achieving/maintaining prompt response to customer orders | | .866 | | |
| c- Offering extensive customer service. | | .743 | | |
| 3-Firm Knowledge | | | | |
| a- Our information gathering technique is very sophisticated. | | | .903 | |
| b- We use salesforce reports and distributor feedback extensively in our channel decisions | | | .887 | |
| 4-Experience | | | | |
| a- Company experience with operating in this export market | | | | .823 |
| b- International orientation of our company's culture. | | | | .870 |
| Cronbachs' alpha | .801 | .779 | .792 | .643 |
| Declared total variance | | | | %77 |

Method of Analysis: Principal Components Analysis.

Rotation Method: Varimax with Kaiser Normalization. Rotation was concluded in 4 iterations.

Table 2: Measurement items

| Measurement item | Factor |
|--|--------|
| Business export performance | |
| a- Export sales volume (unit sales) | .879 |
| b- Export sales revenue | .807 |
| c- Exporter profitability | .843 |
| d- Market share in the main importing market | .851 |
| Cronbachs' alpha | .861 |
| Declared total variance | %77 |

Method of Analysis: Principal Components Analysis.

Rotation Method: Varimax with Kaiser Normalization. Rotation was concluded in 4 iterations.

Table 3: Means, standard deviations and Pearson correlation of variables

| Measure | Mean | S.D. | F1 | F2 | F3 | F4 | F5 |
|---------------------------|------|-------|--------|--------|--------|--------|----|
| 1.Distribution capability | 3,31 | 0,678 | - | | | | |
| 2.Service differentiation | 4,12 | 0,679 | ,304** | - | | | |
| 3.Business knowledge | 3,62 | 0,467 | ,412** | ,255** | - | | |
| 4.Experience | | 3,90 | 0,734 | ,360** | ,519** | ,262** | - |
| 5.Business performance | 3,82 | 0,731 | ,472** | ,558** | ,374** | ,498** | - |

* Significant at $p < 0.05$. (two-sided)

** Significant at $p < 0.01$. (two-sided)

To observe the factorial distribution and loads of four independent variables where there are features belonging to businesses a set of factor analysis were carried out and the results obtained are as follows. As expected, questions were separated into four factors and the factor loads occurred over 0,5. The declared total variance is 77,30%. In Cronbach's alpha reliability test, which was done after crosschecking the validity of the scales, the coefficients occurred over 0.60. Accordingly, distribution capability is 0,801, service differentiation is 0,779, business knowledge is 0,792 and experience is 0,643. These values is above the 0,60 value specified by Bagozzi and Yi (1998). Factorial distribution, loads and the results of reliability analysis are shown in Table 1. And Table 2 includes the results of factor and reliability analysis of dependent variables. It is seen that total declared variance in factor analysis is 77% and that factor loads are satisfactorily loaded to the related variables. Alpha reliability coefficients was 0.861 and Business Performance. In the correlation analysis in Table

3, the correlation between the variables is analyzed and below mentioned results are obtained. A positive correlation between service differentiation and distribution capability ($\beta=30,4^*$), business knowledge and distribution capability ($\beta=41,2^{**}$), business knowledge and service differentiation ($\beta=25,5^{**}$), experience and distribution capability ($\beta=36,0^{**}$), experience and service differentiation ($\beta=51,9^{**}$), experience and business knowledge ($\beta=26,2^{**}$), business performance and distribution capability ($\beta=47,2^{**}$), business performance and service differentiation factor ($\beta=55,8^{**}$), business performance and business knowledge ($\beta=37,4^{**}$), business performance and experience factor ($\beta=49,8^{**}$) was found, double asterisk (**) indicating .01, single asterisk (*) .05 significance level. The theoretic model of the study is analyzed with a single-stage hierarchical regression model and the results are shown in Table 4. In the model where business performance is the dependent variable adjusted R square is found as 0.434 and F value as 21,567 ** . R square value obtained as a result of the analysis, shows that independent variables used in the model explains 43% of the variance in business performance. It can be said that this regression equation is significant. Accordingly, distribution capability ($\beta=0.258$) (Sig.=0,005 **), service differentiation ($\beta=0.376$) (Sig.=0,000 **), business knowledge ($\beta=0.212$) (Sig.=0,097 **) and experience ($\beta=0.162$) (Sig.=0,029 **) positively impact the increasing of the financial performance of a business at these significance levels. In line with these results H1a H2a H3a and H4a hypothesis were approved.

Table 4: Regressions results

| Independent Variables | Standardized | | | Dependent Variable |
|--|--------------|-------|------|-----------------------------|
| | Coefficients | | | |
| | β | t | Sig. | |
| Distribution capability | ,258 | 2,866 | ,005 | Business export performance |
| Service differentiation | ,376 | ,350 | ,000 | |
| Business knowledge | ,212 | ,135 | ,097 | |
| Experience | ,162 | ,194 | ,029 | |
| Adjusted R ² : 0,434; F: 21,567 ** | | | | |

* Significant at $p<0.05$.

** Significant at $p<0.01$.

As it is seen in Table 4, when the impacts of all the variables discussed on the business export performance is looked into, it is seen that distribution capability, that significantly effects performance, occurred as (beta =.258; $p<0.01$), service differentiation as (beta =.376; $p<0.01$), business knowledge as (beta =.212; $p<0.01$) and experience as (beta =.162; $p<0.01$).

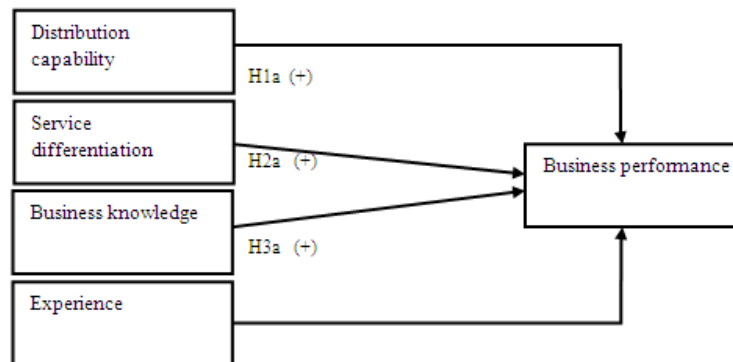

Fig. 2: Path Analysis Results

Our study aims at analyzing the effects of distribution capability, service differentiation, business knowledge, experience and business export performance on the performance of the business itself and consequently on the exporter business export performance. At the end of the study, it is found that all four behaviours- distribution capability, service differentiation, business knowledge and experience- improved the efficiency of the business (e.g., ROS and ROA). Thus, if the company has larger distribution capability, provides differentiation in its services in responding the expectations of its customers and increases its experience-based knowledge in increasing its sales revenue and improving its performance by this way, it will also increase its financial performance. Besides, financial advantage can be taken by getting distribution capability. Thus, as we increase the distribution capability so will the financial performance. This result complies with previous studies (Day and Wensley, 1988; Richey and Matthew, 2001). As it is seen in Table 4, the effects of distribution capability, service differentiation, business knowledge and experience factors on business export performance were examined. If the business is strong in product distribution and provides

service differentiation via its business knowledge and increases its experience in the market, these will provide a financial advantage for the company. This is because the increase in business experience and in the ability to use market information will lead to decrease in the communication and coordination costs of the business, in labor costs and staff expenses, operational and business costs; and additionally in inventory costs and in this respect the result obtained is significant. Increasing distribution capability ensures on-time delivery of the exporters' products to the clients and taking measures against unestimated costs. Thus, the business can make efficient planning and decrease its distribution costs (Richey and Matthew, 2001). In increasing business performance, service differentiation and distribution capability are regarded as significant factors. On the other hand, business knowledge and experience can be expected to be more effective in business export performance. The fact that these two factors are found to be at a less significance level is interesting. Accordingly, it can be said that businesses put more emphasis on distribution capability and service differentiation financially rather than having & using business knowledge and experience. Actually the experience of the business provides both cost advantage and increases financial performance (Toften, 2005). This result is an indicator of the importance of market experience. Therefore, gaining and using market knowledge is seen as important for the exporters. As a result of using this information day by day following the acquisition of it, generalized behavior and action plans are made and this not only provides cost advantage to the business but also increases financial gains by cost cutting.

5. Limitations and Conclusion:

In many studies in the literature, it is mostly European and American businesses that were tested in measuring the business export performance. In order to contribute to the generalization of the studies done in those countries, it will be useful to test the behaviors of the businesses in developing countries. Turkey has been a rapidly growing country lately as well as a significant attraction center for foreign investments. In this respect, testing the performances of the businesses in Turkey will not only contribute to the generalization of previous studies but also support the determination of behaviors of Turkish businesses that create value. One of the results of this study is that businesses pay serious attention to service differentiation. Besides, selling price, payment and credit terms and channel margins are regarded as advantages for the businesses in export markets. So in order to increase their export performance, the businesses should be planning which behaviors provide which advantages and make their plans and programs accordingly. New researches can be done in this area by including various variables in the future. By including firm orientation, export planning, product development capability to the variables tested in this study, the financial performance of the business should be analyzed. Adding these variables to the model will contribute to the generalization. In this research, financial performance is limited to own behaviors of the business. However, external factors effecting the costs and competition ability of the business should also be considered. Foreign trade and incentive policies of governments (Czinkota and Ronkainen, 1995) are of great importance on the business behaviors. Legal incentives or preventions impact foreign trade performance. So, the foreign trade regulations and quotas of the countries should also be considered in the researches to be done. On the other hand, this research is done on machine, textile and furniture companies in Marmara and Aegean regions which are engaged in export business. To make a generalization of the results obtained, new studies can be done in other regions and on other manufacturing industries. Thus, experience, service differentiation, distribution capability and business knowledge variables, which have positive impacts on financial performance of businesses, will be analyzed again. As a result, increasing their market knowledge and experience and distribution capability; and creating service differentiation to increase the export sales volume, revenue, profitability and in short the overall export performance of businesses will make a positive contribution to increasing the financial performance and thus, increase their competitive power.

REFERENCES

- Aaby, N.E., S.F. Slater, 1989. Managerial influences on export performance – a review of the empirical literature 1978-88. *Int. Mark. Rev.*, 6(4): 53-68.
- Aaker, D.A., 1991. *Building brand equity*. New York: The Free Press.
- Anderson, E., G.S. Day and V.K. Rangan, 1997. Strategic channel design. *Sloan Manage. Rev.*, 38(4): 59-69.
- Antti, H., M. Vivekananda, Y. Ugur, B. Emin, 2005. Cooperative strategy, knowledge intensity and export performance of small and medium sized enterprises. *J. of World Bus.*, 40:124-138.
- Bagozzi, R.P., Y. YI, 1988. On the evaluation of structural equation models. *J. of Academy of Mark. S.*, 16 (Spring): 74-94.
- Barney, J.B., 1991. Firm resources and sustained competitive advantage, *J. of Manage.*, 17: 99-120.
- Bharadwaj, S.G., P.R. Varadarajan, J. Fahy, 1993. Sustainable competitive advantage in service industries: a conceptual model and research propositions. *J. Mark.*, 57: 83-99.

- Bilkey, W., G. Tesar, 1977. The export behavior of smaller-sized Wisconsin manufacturing firms. *J. Int. Bus. Stud.* 93– 8 (Spring/Summer).
- Bilkey, W., 1978. An attempted integration of the literature on the export behavior of firms. *J. Int. Bus. Stud.*; 33– 46 (Spring/Summer).
- Blesa, A., M. Ripollés, 2008. The influence of marketing capabilities on economic international performance. *I. Mark. Rev.*, 25: 6.
- Burridge, M., R. Bradshaw, 2001. Practices of successful small and medium successful exporters: the use of market information. *J. of Small Bus. and Enterp. Deve.*, 8(3): 267-74.
- Calantone, R.J., D. Kim, J.B. Schmidt, S.T. Cavusgil, 2006. The influence of internal and external firm factors on international product adaptation strategy and export performance: A three-country comparison. *J. of Bus. Res.*, 59:176-185.
- Catherine, D., 2005. Export market orientation and performance: an analysis of Australian exporters. *anzmac conference: 1: 3-2, Mark.I. and Cross-Cultural Envir.*
- Cavusgil, S.T., S. Zou, 1994. Marketing strategy-performance relationship: an investigation of the empirical link in export market ventures. *J. of Mark.*, 58: 1-21.
- Chetty, S.K., 1999. Dimensions of internationalization of manufacturing firms in the apparel industry International dimensions in the apparel industry. *Eur. J. of Mark.*, 33(1/2): 121-142.
- Kaynak, E., W.K. Kuan, 1993. Environment, strategy, structure, and performance in the context of export activity: an empirical study of Taiwanese manufacturing firms. *J. of Bus. Res.*, 27(1): 33-49.
- Czinkota, M.R., I.A. Ronkainen, 1995. *International marketing*. The Dryden Press. USA.
- Davis, P.S., C.C. Dibrell, B.D. Janz, 2002. The impact of time on the strategy–performance relationship Implications for managers. *Indus. Mark. Manage.*, 31: 339-347.
- Day, G.S., R. Wensley, 1988. Assessing advantage: a framework for diagnosing competitive superiority. *J. Mark.*, 52: 1-20 (April).
- Dean, D.L., B. Mengüç, C.P. Myers, 2000. Revisiting firm characteristics, strategy, and export performance relationship: a survey of the literature and an investigation of New Zealand small manufacturing firms. *Indus. Mark. Manage.*, 29: 461-477.
- Dichtl, E., H.G. Koeglmayr and S. Mueller, 1990. International orientation as a precondition for export success. *J. of Inter. Bus. Stud.*, 21(1): 23-41.
- Evangelista, F.U., 1994. Export performance and its determinants: some empirical evidence from Australian manufacturing firms. *Adv. Int. Mark.*, 6: 207-29.
- Grimes, A., I. Doole, P.J. Kitchen, 2007. Profiling the capabilities of SMEs to compete internationally. *J. of Small Bus. and Enterp. Devel.*, 14(1).
- Katsikeas, C., R.E. Morgan, 1994. Differences in perceptions of exporting problems based on firm size and export market experience. *Eu. J. of Mark.*, 28(5): 17-35.
- Katsikeas, C.S., L.C. Leonidou N.A. Morgan, 2000. Firm-level export performance assessment: review, evaluation, and development. *J. of the Ac. of Mark. S.*, 28(4): 493-511.
- Katsikeas, C.S., S.L. Deng and L.H. Wortzel, 1997. Perceived export success factors of small –medium sized Canadian firms. *J. of Int. Mark.*, 5(4): 53-72.
- Katsikeas, C.S., N.F. Piercy and C. Ioannidis, 1996. Determinants of export performance in a European context. *Eur. J. of Mark.*, 30(6): 6-35.
- Kaynak, E., W.K. Kuan, 1993. Environment, strategy, structure, and performance in the context of export activity: an empirical study of Taiwanese manufacturing firms. *J. of Bus. Res.*, 27(1): 33-49.
- Keng, K.A., T.S. Juang, 1989. Differences between small and medium sized exporting and non-exporting firms: Nature or nurture. *Int. Mark. Rev.*, 6(4): 27-40.
- Toften, K., 2005. The influence of export information use on export knowledge and performance Some empirical evidence. *Mark. Intelligence & Planning*, 23(2): 200-219.
- Lages, L.F., D.B. Montgomery, 2004. Export performance as an antecedent of export commitment and marketing strategy adaptation Evidence from small and medium-sized Exporters. *European Journal of Marketing*, 38 (9/10): 1186-1214.
- Leonidou, L.C., S.K. Constantine, F.P. Nigel, 1998. Identifying managerial influences on exporting: past research and future directions. *J. of Int. Mark.*, 6(2): 74-102.
- Leonidou, L.C., A.K. Anna, 1998. Behavioral aspects of international buyer–seller relationships: their association with export involvement. *Int. Mark. Rev.*, 15(5): 373-97.
- Leonidou, L.C., S.K. Constantine, 1996. The export development process: an integrative review of empirical models. *J. of Int. Bus. Stud.*, 27(3): 517-51.
- Morgan, N.A., A. Kaleka, C.S. Katsikeas, 2004. Antecedents of export venture performance: a theoretical model and empirical assessment. *J. of Mark.*, 68: 90-108.

- Morgan, N.A., S.V. Zou, W. Douglas, C.S. Katsikeas, 2003. Experiential and Informational knowledge, architectural marketing capabilities, and the adaptive performance of export ventures: a cross-national study. *Dec. Scien.*, 34(2): 1-35.
- Morgan, N.A., W.D. Vorhies, B.B. Schlegelmilch, 2006. Resource–performance relationships in industrial export ventures: The role of resource inimitability and substitutability. *Ind. Mark. Manage.*, 35: 621-633.
- Piercy, N.F., A. Kaleka, C.S. Katsikeas, 1998. Sources of competitive advantage in high performing exporting companies. *J. World Bus.*, 4(3): 78-93.
- Porac, J.F., H. Thomas, 1990. Taxonomic mental models in competitor definitions. *Acad. of Manage. Rev.*, 15(2): 224-240.
- Porter, M.E., 1980. *Competitive strategy*. New York: Free Press.
- Porter, M.E., V.E. Millar, 1985. How information gives you competitive advantage. *Harv. Bus. Rev.*, 149-160.
- Richey, R.G., B.M. Matthew, 2001. An investigation of market information use in export channel decisions Antecedents and outcomes, *Int. J. of Phys. Distribution & Log. Manage.*, 31(5): 334-353.
- Rabino, S., 1980. An attitudinal evaluation of an export incentive program: the case of DISC. *Columbia J. World Bus.*: 61– 5 (Spring).
- Roger, J.C., K. Daekwan, B.S. Jeffrey, C. Tamer, 2006. The influence of internal and external firm factors on international product adaptation strategy and export performance: A three- country comparison, *J. of Bus. Res.*, 59: 176-185.
- Rose, M.G., A. Shoham, 2002. Export performance and market orientation Establishing an empirical link. *J. of Bus. Res.*, 55: 217-225.
- Shan, W., J. Song, 1997. Foreign direct investment and the sourcing of technological advantage: evidence from the biotechnology industry, *J. of Int. Bus. Stud.*, 28(2): 267-84.
- Shaoming, Z., F. Eric, Z. Shuming, 2003. The effect of export marketing capabilities on export performance: an investigation of Chinese exporters. *J. of Int. Mark.*, 11(4): 32-55.
- Song, M., R.J. Calantone, C. Benedetto, D. Anthony, 2002. Competitive forces and strategic choice decisions: an experimental investigation in the United States and Japan. *Strategic Manage. J.*, 23: 969-978.
- Srodes, James, 1998. A the UN=s smallbusiness global edge,@ *World Trade*, September, 11(9): 14-15.
- Stanley, F.E., R.J. Calantone, A. Roath, 2000. Meeting quality and cost imperatives in a global market. *Int. J.ofPhy. Distribution & Logistics Manage.*, 30(6): 472-499.
- Stanley, E., P. Fawcet, C. Roger, R.S. Sheldon, 1997. Delivery capability and firm performance in international operations. *Int. J. Production Econ.*, 51: 191-204.
- Toften, K., S.O. Olsen, 2003. Export market information use, organizational knowledge, and firm performance: a conceptual framework. *Int. Mark. Rev.*, 20(1): 95-110.
- Yaprak, A., 1985. An empirical study of the differences between small exporting and non-exporting US firms. *Int. Mark. Rev.*, 2(2): 72-83.
- Zou, S., S. Stan, 1998. The determinants of export performance review of empirical literature between 1987 and 1997. *Int. Mark. Rev.*, 15(5): 333-56.
- Zou, S., E. Fang, S. Zhao, 2003. The effect of export marketing capabilities on export performance: an investigation of Chinese exporters. *J. of Int. Mark.*, 11(4): 32-55.